

IM-21 MOTORS

DC Permanent Magnet Motors

E-2600

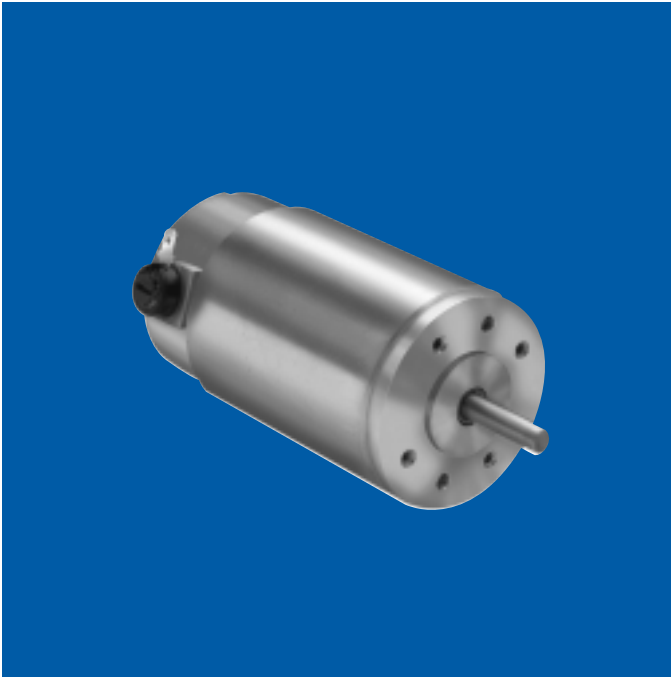

power rating: To .1 hp (74.6 W)
 voltage: 12, 19.1, 24, 30.3 standard windings
 weight: 26 to 46 ozs.
 armature: Skewed for lower cogging torque
 inertia: See table, opposite page
 electrical time constant: 1.6 milliseconds max
 mechanical time constant: 10 milliseconds max
 typical no load torque: 2.0 oz. in.
 shaft: Precision-ground and hardened stainless steel.
 Options: length, flats, pinions, gears
 terminals: Tab type to mate with Amp 187 series push-on receptacles, or equivalent
 magnets: High energy ceramic to withstand high pulse currents without demagnetizing
 bearings:

Ball: Pre-loaded to withstand higher side loads and low end play
 Sleeve: Self-aligning and life lubricated to withstand a 2-lb. side load with .003" to .040" axial end play

cover: Steel housing
 end bells: Die-cast zinc
 winding insulation rating: 180°C
 winding temperature rise: ***See chart, opposite page
 options available:
 • EMI suppression
 • Optical encoders

Dimensions

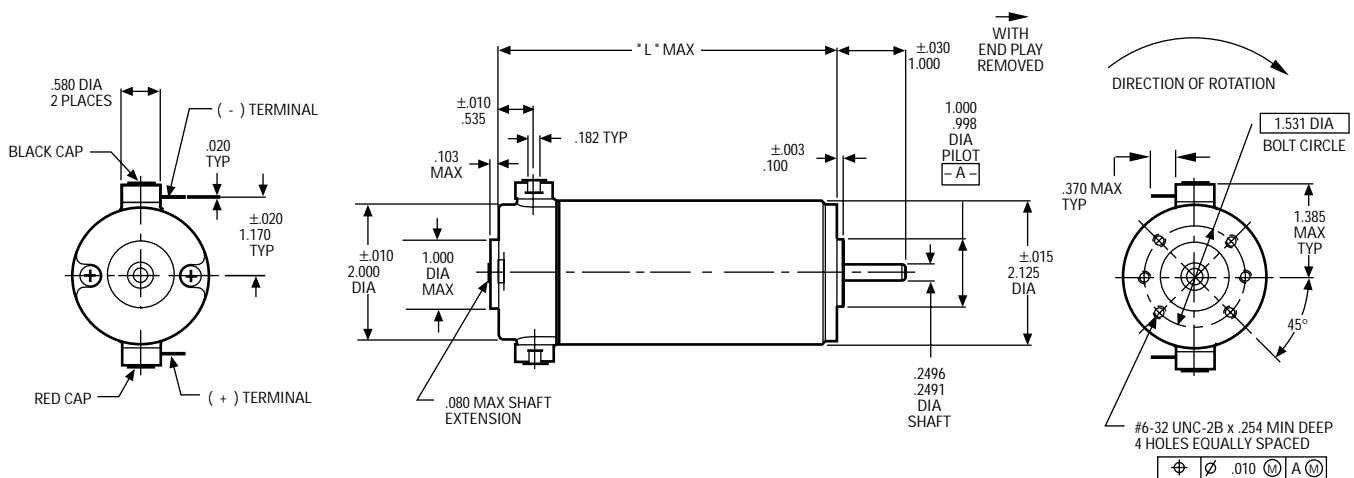

ROTATION (VIEWED FROM SHAFT END)
 CW - POSITIVE VOLTAGE TO (+) NEGATIVE VOLTAGE TO (-)
 CCW - REVERSE POLARITY

NOTE: Consult factory prior to preparing spec control prints. Dimensions are for reference only.

Standard Part Numbers and Data

| VOLTAGE (VDC) | A | | B | | C | | | D | | | STANDARD PART NUMBERS* | |
|------------------------------|--------------------------|----------------------------|---------------------------------------|----------------------------|-------------------------------|---------------------------------|-------------------------------------|------------------------------|---|----------------------------|------------------------|-----------------|
| | SPEED ±10% no load (rpm) | TORQUE (oz. in.) max rated | TORQUE (oz. in.) ** theoretical stall | CURRENT (amps) max no load | CURRENT (amps) max rated load | CURRENT (amps) ** nominal stall | TORQUE CONSTANT K_T (oz. in./amp) | TERMINAL RESISTANCE R (ohms) | INERTIA (oz. in. sec ²) x10 ⁻³ | TEMP. RISE (***) (°C/watt) | | |
| Motor Length "L" Max. 3.203" | | | | | | | | | | | ball bearings | sleeve bearings |
| 12.0 | 4200 | 15 | 95 | .63 | 5.4 | 20.7 | 3.82 | 0.58 | 2.0 | 6.0 | 537A131-1 | 537A136-1 |
| 19.1 | | | | .41 | 3.5 | 16.5 | 5.88 | 1.16 | | | -2 | -2 |
| 24.0 | | | | .32 | 2.7 | 12.8 | 7.56 | 1.87 | | | -3 | -3 |
| 30.3 | | | | .26 | 2.4 | 10.3 | 9.45 | 2.95 | | | -4 | -4 |
| Motor Length "L" Max. 3.703" | | | | | | | | | | | | |
| 12.0 | 3700 | 20 | 140 | .60 | 6.1 | 26.7 | 4.28 | 0.45 | 2.9 | 5.6 | 537A132-1 | 537A137-1 |
| 19.1 | | | | .38 | 3.9 | 21.2 | 6.76 | 0.90 | | | -2 | -2 |
| 24.0 | | | | .30 | 3.1 | 16.7 | 8.60 | 1.44 | | | -3 | -3 |
| 30.3 | | | | .23 | 2.4 | 13.0 | 11.06 | 2.34 | | | -4 | -4 |
| Motor Length "L" Max. 4.078" | | | | | | | | | | | | |
| 12.0 | 3750 | 24 | 190 | .63 | 7.4 | 34.3 | 4.15 | 0.35 | 3.4 | 4.7 | 537A133-1 | 537A138-1 |
| 19.1 | | | | .39 | 4.5 | 27.7 | 6.99 | 0.69 | | | -2 | -2 |
| 24.0 | | | | .32 | 3.7 | 22.6 | 8.54 | 1.06 | | | -3 | -3 |
| 30.3 | | | | .26 | 2.9 | 17.7 | 10.87 | 1.71 | | | -4 | -4 |
| Motor Length "L" Max. 4.453" | | | | | | | | | | | | |
| 12.0 | 3100 | 30 | 220 | .56 | 7.5 | 35.3 | 5.18 | 0.34 | 4.1 | 4.3 | 537A134-1 | 537A139-1 |
| 19.1 | | | | .33 | 4.6 | 26.9 | 8.46 | 0.71 | | | -2 | -2 |
| 24.0 | | | | .27 | 3.8 | 21.8 | 10.35 | 1.10 | | | -3 | -3 |
| 30.3 | | | | .21 | 3.0 | 17.1 | 13.17 | 1.77 | | | -4 | -4 |
| Motor Length "L" Max. 4.953" | | | | | | | | | | | | |
| 12.0 | 3175 | 35 | 290 | .47 | 8.8 | 46.2 | 5.15 | 0.26 | 5.0 | 4.0 | 537A135-1 | 537A140-1 |
| 19.1 | | | | .38 | 5.7 | 37.5 | 7.90 | 0.51 | | | -2 | -2 |
| 24.0 | | | | .30 | 4.4 | 28.9 | 10.15 | 0.83 | | | -3 | -3 |
| 30.3 | | | | .23 | 3.4 | 22.6 | 12.97 | 1.34 | | | -4 | -4 |

** Because of brush drop and field distortion, current and torque indicated will not always be attainable

*** Winding temperature rise measured when mounted to 8.00" x .25" aluminum plate. Multiply by 1.4 when mounted to a heat insulator.

*When You Order

Units shown above are standard and may be ordered by part number. Remember to include armature winding dash number, EXAMPLE: 537A131-1

Typical Motor Performance

Part No.: 537A131-1

Voltage: 12 VDC

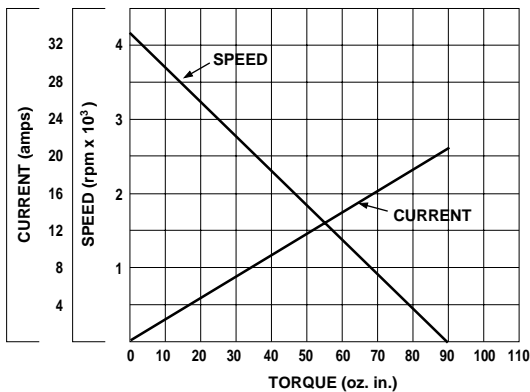

Part No.: 537A135-3

Voltage: 24 VDC

