

SC & MC BLOWERS

AC Tubeaxial Blowers

C-4166

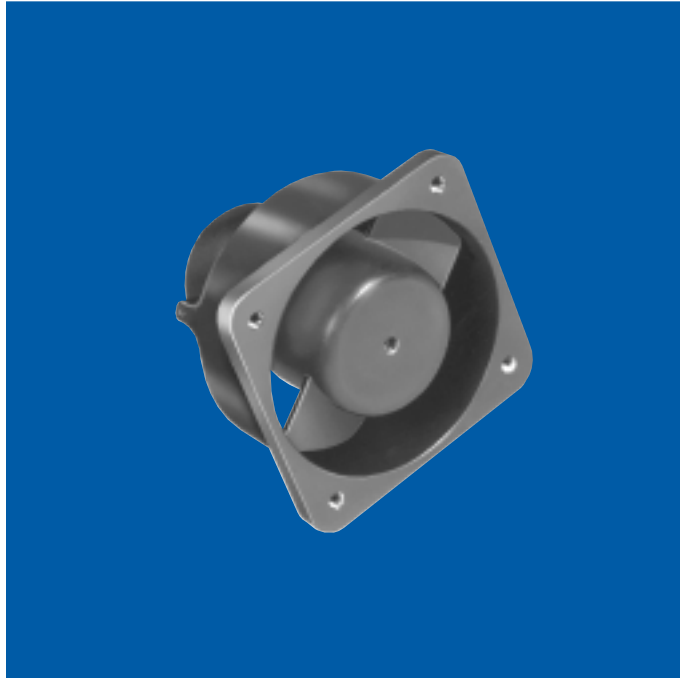

general design specification: Motor to MIL-M-7969

airflow: Up to 62 cfm (29.3 L/sec.) @ free air

voltage: 115 VAC; 60 and 400 Hz

impeller: Dynamically balanced, precision-cast aluminum

housing: Precision-cast aluminum

bearings: Double shielded, life-lubricated for -55°C to +85°C operation. Special lubricants available for temperature extremes

cables/leads: 8" #26 AWG min. per MIL-W-16878/4 exposed length

mounting: Standard mounting is with tapped holes in flange of base

marking: Per MIL-STD-130

life: 1,000 hours min at 71°C

Dimensions

TYPE SC

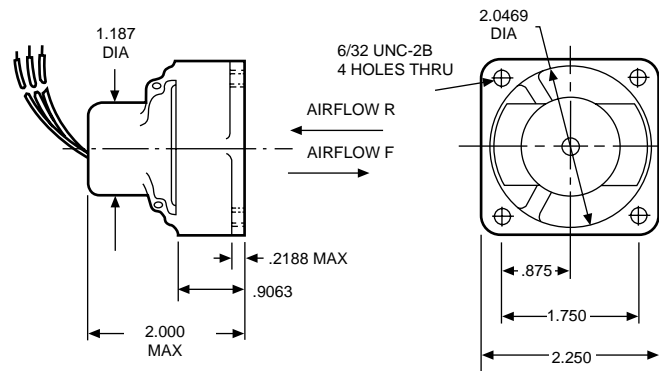

TYPE MC

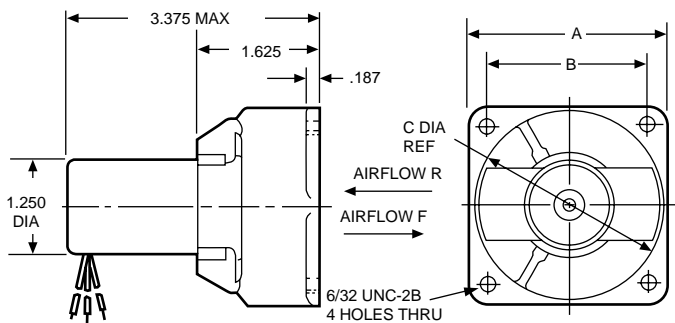

TYPE MC DIMENSIONS			STANDARD PART NUMBERS*	
A (in.)	B (in.)	C (in.)	(airflow R)	(airflow F)
2.625	2.125	2.500	19A533	19A540
			19A526	19A527
2.250	1.750	2.047	19A590	19A591

NOTE: Consult factory prior to preparing spec control prints. Dimensions are for reference only

Standard Part Numbers and Data

	TYPE	VOLTAGE (VAC)	FREQUENCY (Hz)	PHASE	SPEED min @ free air (rpm)	AIRFLOW min @ free air (cfm)	POWER INPUT max (watts)	WEIGHT max (oz.)	SCHEMATIC	VARIABLE	CAPACITOR (μF) (wvdc)		STANDARD PART NUMBER*
AIRFLOW F	SC	200	400	3	15,000	45	30	5.0	B	BRN	—	—	19A653-3
		115	400	1 or 3	15,000	45	30	5.0	B	BLK	.800	600	19A653-1
		27	400	1 or 3	15,000	45	30	5.0	B	WHT	12.000	100	19A653-2
	SC	200	400	3	9,800	30	12	5.0	A	BRN	—	—	19A651-3
		115	400	1 or 3	9,800	30	12	5.0	A	BLK	.330	400	19A651-1
		27	400	1 or 3	9,800	30	12	5.0	A	WHT	5.000	100	19A651-2
	MC	115	400	1	11,800	37	14	8.5	C	BLK	.068	1,000	19A591
		115	400	1	11,000	62	20	9.0	C	RED	.080	1,000	19A527
		115	60	1	3,600	20	11	9.0	D	—	.500	300	19A540
AIRFLOW R	SC	200	400	3	15,000	50	30	5.0	B	BRN	—	—	19A652-3
		115	400	1 or 3	15,000	50	30	5.0	B	BLK	.800	600	19A652-1
		27	400	1 or 3	15,000	50	30	5.0	B	WHT	12.000	100	19A652-2
	SC	200	400	3	9,800	30	12	5.0	A	BRN	—	—	19A650-3
		115	400	1 or 3	9,800	30	12	5.0	A	BLK	.330	400	19A650-1
		27	400	1 or 3	9,800	30	12	5.0	A	WHT	5.000	100	19A650-2
	MC	115	400	1	11,800	37	14	8.5	C	BLK	.068	1,000	19A590
		115	400	1	11,000	58	20	9.0	C	BLK	.080	1,000	19A526
		115	60	1	3,600	20	11	9.0	D	—	.500	300	19A533

Note: All 3-phase voltages are line to line. MIL-STD-704 is 200V line to line

*When You Order

Units shown above are standard and may be ordered by part number. Motor windings, voltage, frequency, speed, current and airflow can usually be modified to fit your needs

Typical Performance

Part Nos.: 19A526
19A527

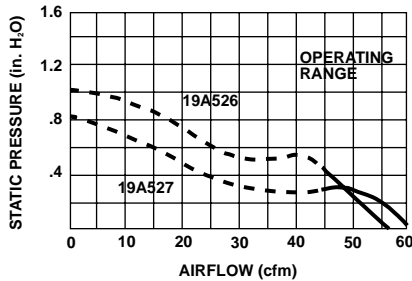

Part Nos.: 19A590
19A591

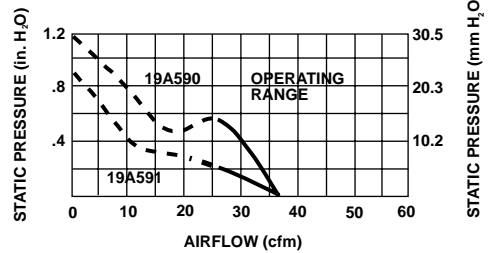

Part Nos.: 19A533
19A540

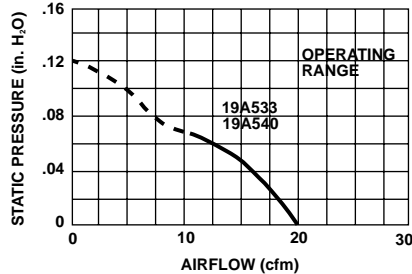

Part Nos.: 19A650
19A651
19A652
19A653

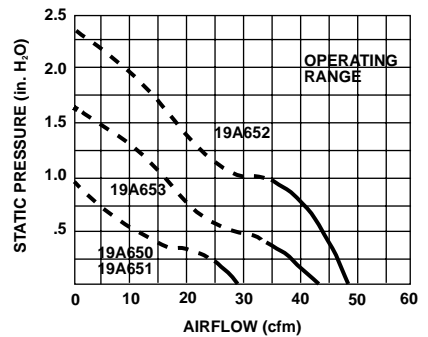

Schematic Wiring

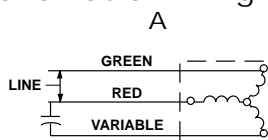

CCW ROTATION VIEWED FROM IMPELLER END
3 PHASE SEQUENCE
VARIABLE-RED-GREEN

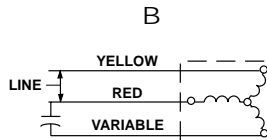

CCW ROTATION VIEWED FROM IMPELLER END
3 PHASE SEQUENCE
VARIABLE-RED-YELLOW

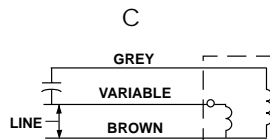

CCW ROTATION VIEWED FROM IMPELLER END

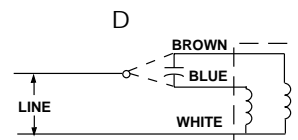

P/N 19A533 CONNECT LINE TO WHITE & BLUE FOR CCW ROTATION VIEWED FROM IMPELLER END
P/N 19A540 CONNECT LINE TO WHITE & BROWN FOR CW ROTATION VIEWED FROM IMPELLER END